

S SERIES

CLARK[®]
THE FORKLIFT

S20C/25C/30C/32C

LPG engine

Cushion Tyres

2000 kg 2500 kg 3000 kg 3200 kg

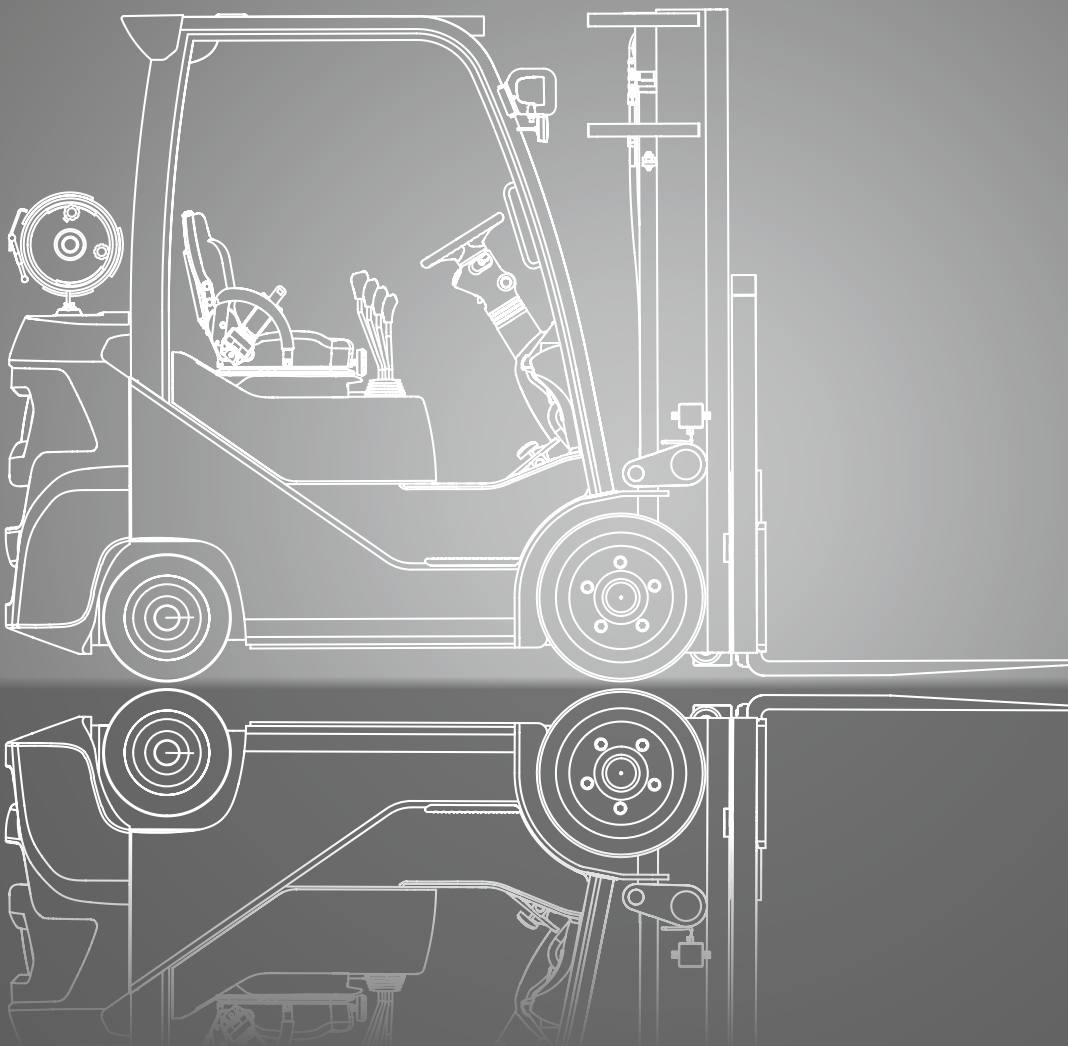

DIMENSIONS

S20C/25C/30C/32C

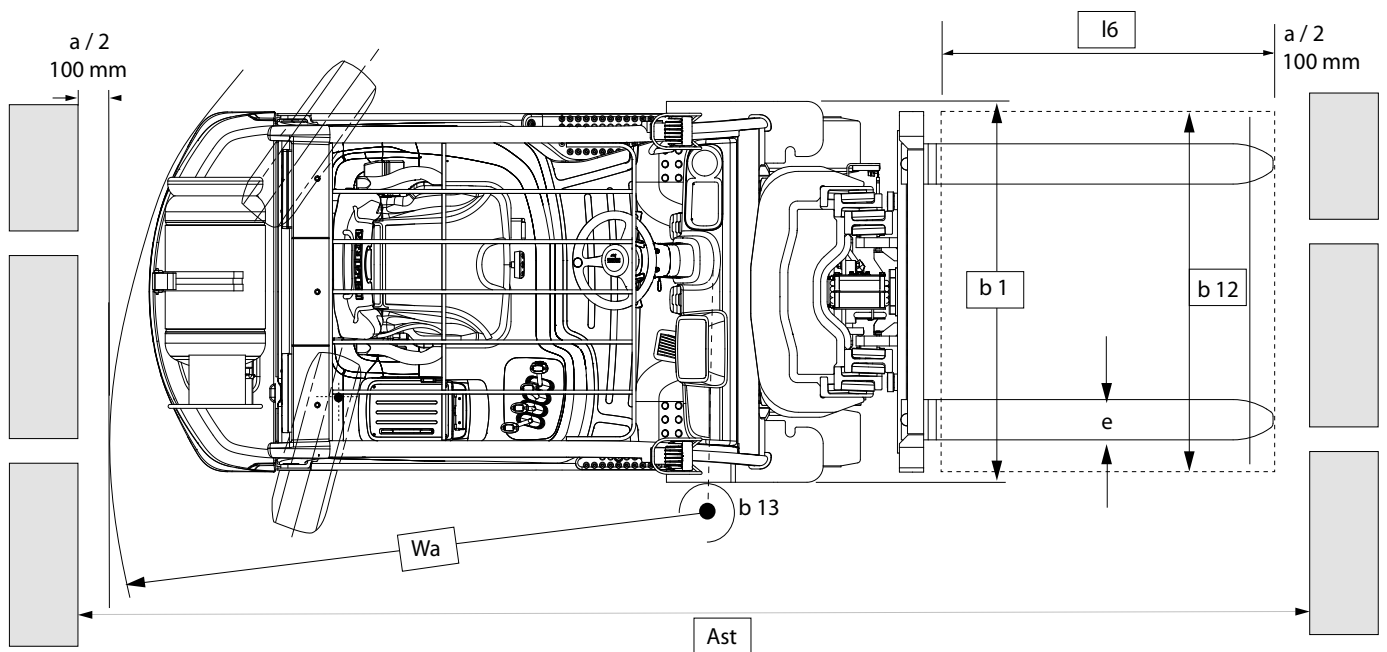
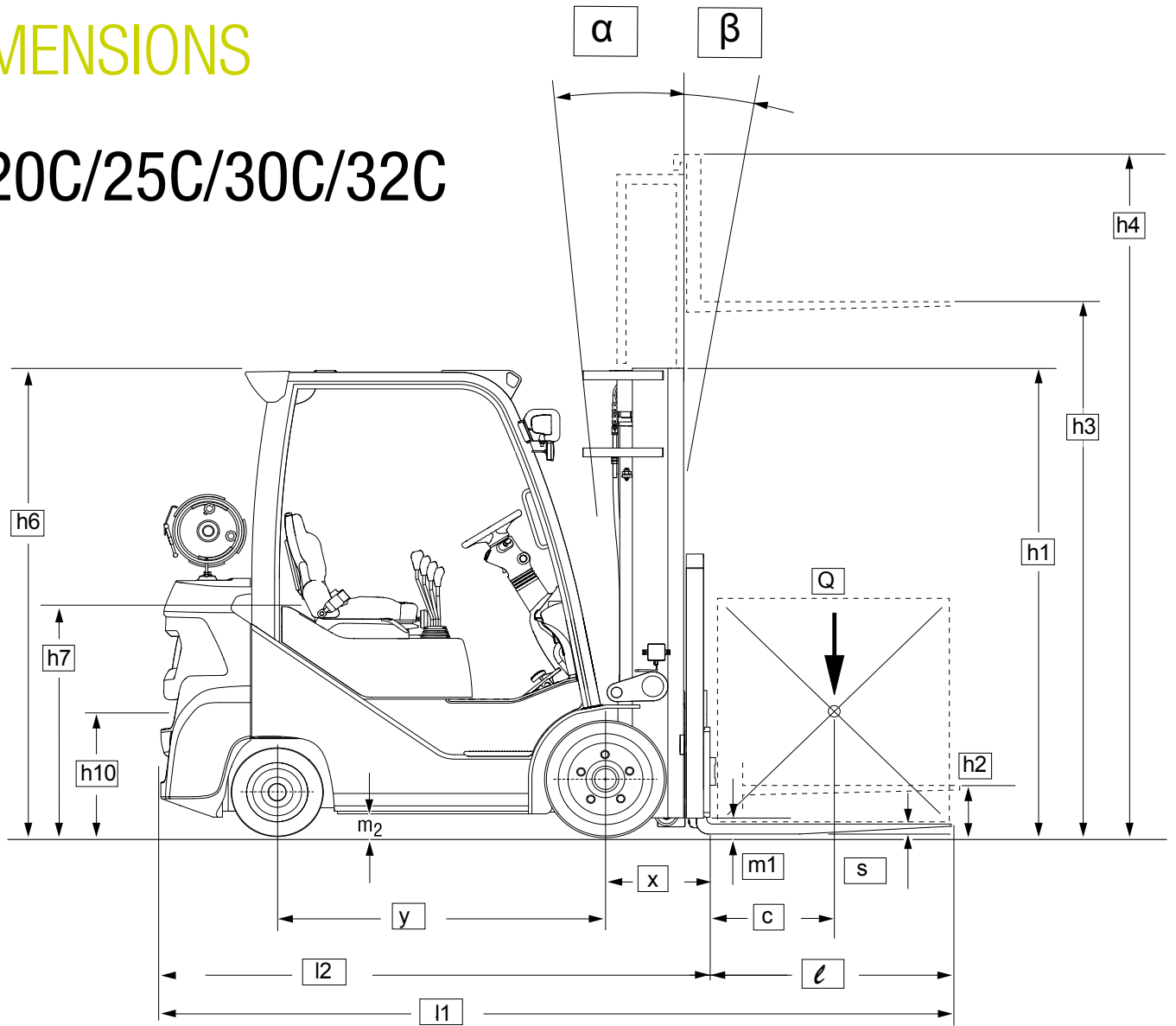

For corresponding data see specification chart.

$a = 200 \text{ mm}$
 $Ast = Wa + x + l_6 + a$
 applies only if $b_{12}/2 < b_{13}$

SPECIFICATIONS

Product Specifications acc. to VDI 2198

1.1 Manufacturer (Abbreviation)		CLARK	CLARK	CLARK	CLARK
Specifications	1.2 Manufacturer's designation	S20CL	S25CL	S30CL	S32CL
	1.3 Drive unit Diesel, L.P. Gas	LPG	LPG	LPG	LPG
	1.4 Operator type stand on/driver seated	Driver Seated	Driver Seated	Driver Seated	Driver Seated
	1.5 Load capacity/rated load Q (kg)	2000	2500	3000	3200
	1.6 Load centre distance c (mm)	500	500	500	500
	1.8 Load centre distance, centre of drive axle to fork face x (mm)	409	409	409	414
	1.9 Wheelbase y (mm)	1430	1430	1430	1430
Weight	2.1 Service weight kg	3430	3802	4219	4428
	2.2 Axle loading, laden front/rear kg	4658 / 772	5370 / 932	6188 / 1031	6526 / 1102
	2.3 Axle loading, unladen front/rear kg	1387 / 2043	1280 / 2521	1281 / 2938	1281 / 3148
Tyres, Chassis	3.1 Tyre type *1	B	B	B	B
	3.2 Tyre size, front	21 X 7	21 X 7	21 X 8	21 X 9
	3.3 Tyre size, rear	16 X 5-10.5	16 X 5-10.5	16 X 6-10.5	16 X 6-10.5
	3.5 Wheels, number front/rear (x = drive wheels)	2 x / 2	2 x / 2	2 / 2	2 / 2
	3.6 Tread, front b10 (mm)	884	884	909	926
	3.7 Tread, rear b11 (mm)	895	895	920	920
	Dimensions	4.1 Tilt of upright $\alpha = \text{back} / \beta = \text{front}$ Grad	10 / 8	10 / 8	10 / 8
4.2 Height, upright lowered h1(mm)		2115	2115	2115	2115
4.3 Freelift h2(mm)		110	110	110	115
4.4 Lift height *2 h3(mm)		3300	3300	3300	3165
4.5 Height, upright extended (with load backrest) h4(mm)		3854	3854	3903	3824
4.7 Height overheadguard h6(mm)		2105	2105	2105	2105
Height overheadguard with cab h6(mm)		2125	2125	2125	2125
4.8 Seat height h7(mm)		1113	1113	1113	1113
4.12 Coupling height h10(mm)		310	310	310	310
4.19 Overall length l1(mm)		3364	3414	3468	3501
4.20 Length to face of forks l2(mm)		2294	2344	2398	2431
4.21 Width (wide drive/dual drive) b1, b2 (mm)		1060 (1239)	1060 (1239)	1114 (1290)	1155
4.22 Fork dimensions s • e • l (mm)		45 x 100 x 1070	45 x 100 x 1070	45 x 122 x 1070	50 x 125 x 1070
4.23 Fork carriage DIN 15173, A, B		Class II A	Class II A	Class III A	Class III A
4.24 Fork carriage width b3 (mm)		940	940	1040	1040
4.31 Ground clearance minimum m1 (mm)		85	85	85	85
4.32 Ground clearance centre of wheelbase m2 (mm)	110	110	110	110	
4.33 Aisle width for pallets 1000x1200 crossways Ast(mm)	3630	3671	3719	3762	
4.34 Aisle width for pallets 800x1200 lengthways Ast(mm)	3829	3870	3918	3961	
4.35 Turning radius (mm)	2020	2061	2109	2147	
4.36 Internal turning radius b13 (mm)	545	545	545	545	
Performances	5.1 Travel speed laden/unladen km/h	18.1 / 18.5	18.0 / 18.5	17.9 / 18.4	18.0 / 18.6
	5.2 Lift speed laden/unladen m/s	0.52 / 0.54	0.52 / 0.54	0.52 / 0.54	0.43 / 0.45
	5.3 Lowering speed laden/unladen m/s	0.55 / 0.50	0.55 / 0.50	0.55 / 0.50	0.47 / 0.43
	5.6 Max. drawbar pull laden/unladen *3 N	20.652 / 8.306	20.584 / 7.668	20.476 / 7.158	20.260 / 7.021
	5.8 Max. gradeability laden/unladen *3 %	39.8 / 22.1	33.8 / 18.8	29.0 / 16.1	27.3 / 14.8
	5.9 Acceleration time laden/unladen (0 -15 m) s	-	-	-	-
5.10 Service brake	Wet disc brake	Wet disc brake	Wet disc brake	Wet disc brake	
Engine	7.1 Manufacturer/Type *6	FORD	FORD	FORD	FORD
	7.2 Rated output acc. DIN 70 020 kW	52	52	52	52
	7.3 Rated speed acc. DIN 70 020 min-1	2500	2500	2500	2500
	7.4 No. of cylinders/displacement /cm3	4 / 2488	4 / 2488	4 / 2488	4 / 2488
	7.5 Fuel consumption acc. VDI-Cyclus Diesel = l/h, L.P.-Gas = kg/h	-	-	-	-
Misc.	8.2 Operating pressure for attachments *7 bar	Adjustable	Adjustable	Adjustable	Adjustable
	8.3 Oil volume for attachments l/min	max. 35	max. 35	max. 35	max. 35
	8.4 Sound level, driver's ear *4 dB (A)	79	79	79	79
	8.5 Towing coupling, class/type DIN	PIN	PIN	PIN	PIN

*1 Different tyre types available *2 Futher lift heights see upright table *3 with 1.6 km/h Without load at friction coefficient $\mu=0.8$ *4 Equivalent permanent sound-pressure level L pAeq, T in accordance with DIN EN 12053 (previously DIN 45635-36) *5 Values for Wide Drive Tyre (Option) *6 LPG= Stage 4 *7 Max. 140 bar

All values shown are for standard lift truck with standard equipment. If the truck is supplied with options, values may change.

All values given may vary + 5 % and - 10 % due the motor and system tolerances and represent nominal values obtained under typical operating conditions.

PRODUCT DESCRIPTION



The S-Series from CLARK marks a further development in reliable, durable and powerful forklifts. Lower operating and maintenance costs combined with a well-designed and ergonomic operator compartment are what makes this forklift truly unique.

Driver Environment

- Functional, safe with minimal vibrations
- Low positioned perforated non-slip metal step
- Fully covered anti-slip rubber foot area
- A grab handle on the driver side of entry makes it easy to climb up and down
- Adjustable steering column allows more leg and foot room
- Small steering wheel diameter ($\varnothing=300$ mm)
- Hydraulic power steering
- Adjustable artificial leather vinyl seat with mechanical suspension weight adjustable from 50 to 140 kg
- Engine cover mounted hydraulic control levers or as an optional armrest mini lever
- Automotive style foot pedals
- Low front cowl for improved visibility
- Excellent visibility from a new developed driver's roof
- Cup holder, storage box and document holder including a 12V power connection

Smart-Display

- Clear and easy-to-read 5-inch colour display
- Protected against water ingress
- Maintenance indicator and password-protected service access
- Selection of different warning signs (optical / acoustic)

Fuel efficiency truck management options

- Automatic engine shut down timer for excessive engine idling
- Automatic light switch-off
 - The setting for each shutdown function can be activated on demand and will be set after operator has left the driver seat
 - The shutdown timer delay is adjustable

Engine, Transmission

The CLARK S-Series forklifts with LPG power offer excellent acceleration and performance power. These modern engines are efficient and at the top end of the performance class. Temperature from the engine and transmission is constantly monitored and in the event of design limits being exceeded the engine is automatically shut-down. Rubber mounted transmission and drive axle, separated by a heavy duty flexible coupling, reduces vibrations and noise to a minimum.

LPG Engine

- FORD (2.5L)
- ECU-controlled map ignition for more torque
- 4-cylinder design with overhead camshafts
- Electronic controlled engine speed

Steering system

- Hydrostatic power steering eliminating steering kick-back
- A robust steering axle with pivotal bearings in mounted rubber steel moulded mounting

Brake system

- Maintenance free wet disc service brakes
- Power assisted service brake for easier brake operation with more effect
- Automatic parking brake

Hydraulic system

- Full-flow reverse filter, filters the oil to the tank at each reverse flow
- Rough particles are filtered directly via a suction filter, thereby preventing them from entering the oil circuit, ensuring a long service life for all hydraulic components
- Large hydraulic oil tank makes sure that there is always enough hydraulic oil available for the highest upright and all attachments
- A safety valve provides extra safety and prevents an uncontrolled load lowering at all times

Upright

- The clear-view uprights are available in Standard, Hilo, Triplex and Quad versions
- Perfect view through extra-wide masts, narrow centre cylinders and optimum mast design
- Adjustable sealed canted (Angled) rollers minimize deflection
- Spherical mounted tilt cylinders bearings
- An integral tilt-lock valve prevents mast tilt drift
- Robust 6-roller fork carriage with adjustable side thrust rollers for durability
- A CLARK hydraulic dampening system reduces impacts and vibrations during the transition between the individual lifting sections in raising and lowering, thus protecting the products and extending service life

Additional standard equipment

LED-front headlights, pneumatic tyres, LED-direction indicator lights, combination rear lights with brake lights and white reversing lights. Paintwork in a bright safety colour „CLARK HOT YELLOW GREEN“. Driver's compartment and upright in matt black, rims in gloss black

Additional equipment

- SE tyres
- Various attachments
- Armrest mounted mini-lever with direction control
- Smart travel direction switch mounted on the mechanical hydraulic lever
- Integrated or hook-type side-shifter
- Speed limiter (adjustable from 6 km/h to max. travel speed)
- Rear view camera
- USB charging port in storage box
- Safety light as visual back-up alarm
- Load weight measurement (tolerance: 1% of the rated load)
- CLARK vertical mast system (automatic vertical upright position tilt lock)
- Attachment quick-release couplings
- Various seats with armrest or side wings
- Acoustic reverse alarm
- Reduced overhead guard heights
- Vertical exhaust tail pipe
- ...and much more

Safety

The S-Series is CE certified and conforms to all European safety standards for industrial trucks.

Contact your CLARK dealer to find your optimum forklift.

GENERAL DATA

Truck Capacities Capacity at different load centres

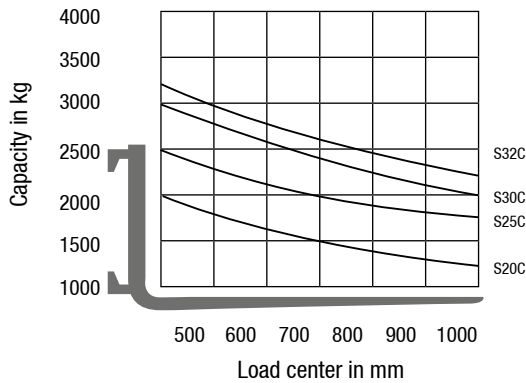

Note:

The listed capacities are valid only for the standard upright in vertical position with standard fork carriage and standard forks, up to max. lifting height of 3300 mm. The centre of gravity of the load may be displaced by max. 100 mm against the longitudinal centre plane of the truck. Load centre is determined from top and front face of the forks. The values are based on a 1000 mm cube load configuration with the centre of gravity at the true centre of the cube. With upright tilted forward lower capacity values are valid. Attachments, longer forks, exceptional load dimensions and higher lifting heights can reduce the capacity.

Please talk to your CLARK dealer if you require further information.

Upright table S20C/25C/30C

	Max.Fork Height (h3)	Mast Lowered (h1)	Mast Extended (h4)		Free Lift (h2)	
			with load backrest	without load backrest	with load backrest	without load backrest
			mm	mm	mm	mm
STD	2120	1525	3340	2663	110	110
	2980	1955	4200	3523		
	3300	2115	4520	3843		
	3500	2255	4720	4043		
	3725	2405	4944	4267		
	3860	2480	5080	4403		
	4165	2750	5384	4707		
	4380	2950	5600	4923		
	4620	3180	5840	5163		
	5170	3445	6390	5713		
Triplex	4320	1955	5539	4873	736	1402
	4500	1985	5719	5053	766	1432
	4800	2115	6019	5353	896	1562
	5210	2255	6429	5763	1036	1702
	5520	2405	6739	6073	1186	1852
	5740	2480	6959	6293	1261	1927
	6100	2640	7319	6653	1421	2087
	6370	2750	7589	6923	1531	2197
	6830	2950	8049	7383	1731	2397
	7315	3180	8534	7868	1961	2627
HI-LO	2935	1955	4155	3489	736	1402
	3255	2115	4475	3809	896	1562
	3530	2255	4750	4084	1036	1702
	3760	2405	4980	4314	1186	1852
	3910	2480	5128	4462	1261	1927
Quad	6100	2115	7332	6686	896	1542
	6560	2260	7784	7138	1041	1687
	7015	2413	8237	7591	1194	1840
	7480	2566	8701	8055	1347	1993
	7935	2718	9156	8510	1499	2145

Upright table S32C

	Max.Fork Height (h3)	Mast Lowered (h1)	Mast Extended (h4)		Free Lift (h2)	
			with load backrest	without load backrest	with load backrest	without load backrest
			mm	mm	mm	mm
STD	2845	1955	4075	3504	115	115
	3165	2115	4395	3824		
	3365	2255	4595	4024		
	3590	2405	4819	4248		
	3725	2480	4955	4384		
	4030	2750	5255	4684		
	Triplex	4140	1955	5363		
4620		2115	5843	5283	896	1456
5030		2255	6253	5693	1036	1596
5340		2405	6563	6003	1186	1746
5560		2480	6783	6223	1261	1821
6190		2750	7409	6849	1531	2091
Quad	6100	2115	7332	6686	896	1542
	6560	2260	7784	7138	1041	1687
	7015	2413	8237	7591	1194	1840
	7480	2566	8701	8055	1347	1993
	7935	2718	9156	8510	1499	2145

Note:

Mast lowered and freelif for S30C are 15mm higher than above mentioned values.

CLARK Europe GmbH
Dr.-Alfred-Herrhausen-Allee 33
47228 Duisburg / Germany
Tel.: +49 (0)2065 499 13-0
Fax: +49 (0)2065 499 13-290
E-Mail: Info-europe@clarkmheu.com
www.clarkmheu.com

Dealer:

05/2018

Nr.: 4581169

Valid for Lot-no.: LPG:10001